

Kinetic Water Ram™

Operating Instructions

**For 1-1/4" through 4" lines
(30mm – 100mm)**



Your Kinetic Water Ram is designed to give you years of trouble-free, profitable service. However, no tool is better than its operator. We therefore suggest that you read these instructions through carefully before using your tool on the job.

This will enable you to operate the Kinetic Water Ram more efficiently and more profitably. Failure to follow these instructions may cause personal injury to operator or damage to equipment.

SAVE THESE INSTRUCTIONS!

General

PIPE CLEANERS

Safety Instructions

The Kinetic Water Ram provides a safe, clean way to clear small pipes and drains. However, as with any tool, certain safety precautions are necessary. Remember these safety rules as you use the Water Ram.



WARNING



- Always wear safety glasses or goggles to protect your eyes from any debris thrown from the drain.
- Never use the tool in a drain with a chemical drain cleaner in it. Any hazardous chemicals in the drain water should be siphoned out or otherwise removed before proceeding.

READ AND UNDERSTAND ALL INSTRUCTIONS!

Failure to follow all instructions listed below may result in serious personal injury.

Call General's customer service department at 412-771-6300 if you have any questions.

What is the Water Ram

The Kinetic Water Ram easily clears debris, sediment, scale, and grease in 1-1/4" to 4" drain lines. It's an ideal tool for maintaining apartment buildings, hotels, schools, universities, restaurants, hospitals, RV and trailer parks, and other locations with multiple drains. It's safer than chemicals, cleaner than snakes, and less expensive and more precise than CO₂ cartridges.

The Water Ram is particularly effective when the stoppage is on the far side of a drum trap or a series of difficult bends that would stop a traditional plumbing snake.

How does it work

The Kinetic Water Ram uses a burst of compressed air, which strikes the column of water in the clogged pipe. The resulting shock wave, called kinetic energy, hits the stoppage at a speed of approximately 4,700 feet per second, quickly clearing the blockage and flushing the waste particles away. Since the shock wave travels so fast, it bypasses vents and stacks, and 98% of the

force hits the clog head-on. There's no pressure build-up in the system, so pipes and joints aren't affected.

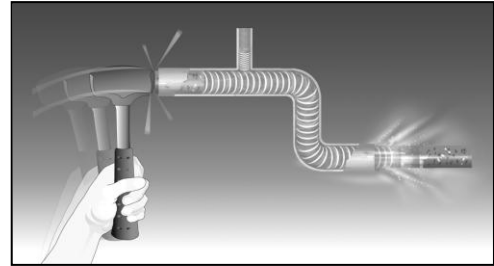

Features

- Built-in air compressor – The Ram pumps up very easily to about 60 lbs.
- Pressure Gauge – Though the pressure gauge can show up to 160 lbs. of pressure, do not use more than 80 lbs. to clear a line.
- Schraeder Valve – For a higher charge of air, use the Schraeder valve and an external compressor.

Standard Accessories

- 4" Tapered Rubber Cone – Fits 1-1/4' to 3" drain openings. Used in most applications.
- Set of 5 Tapered Rubber Plugs – For use when a tighter fit is required in the drain opening. Set includes 1-1/4", 1-1/2", 2", 3" and 4" plugs.
- Caulking Hose – For use when the operator is unable to tightly seal the rubber plug into the drain opening due to the faucet interfering with the Ram.



Optional Accessories

- Toilet Attachment – Enables you to position the cone in the bowl to get a tighter seal. As a result, you can strike the blockage with greater impact and no splash back.

- 6" Tapered Rubber Cone – Fits 1-1/4" to 4" drain openings.
- Expansion Plugs – For use when a tighter seal is needed or when high pressure is needed for clearing extreme blockages. They are available in 1-1/2", 2", 3", and 4" sizes.
- Check Valve Assembly – For use when clearing slow draining sinks and tubs. (Includes Water Supply Hose and Universal Faucet Adapter)

Note: An Instructional Video is available. It covers operation of the Kinetic Water Ram as well as safety procedures. Call for more information.

Assembly

1. Thread the 4" Rubber Cone onto the spindle with the point of the cone facing downward as shown in figure 1, not with the point facing the cylinder as shown in figure 2.

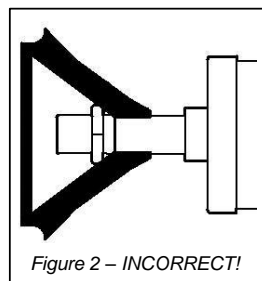
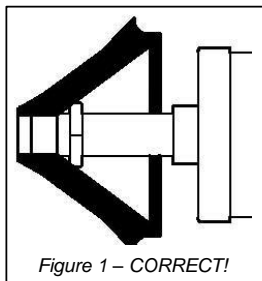

2. The point of the Rubber Cone should be a minimum of 1/4" beyond the end of the spindle.
3. Use the Lock Nut to hold the cone in place as shown in figure 1, *never* as shown in figure 3.

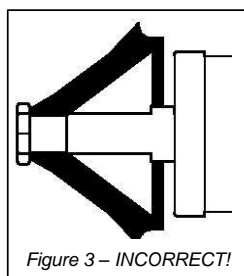

OPERATING INSTRUCTIONS

General Operating Instructions

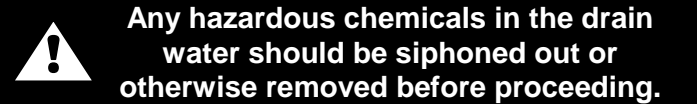

1. Go to the drain or clean-out closest to the stoppage.
2. The Water Ram must hit a solid column of water, not air. If a pipe is only partly blocked and drains slowly, turn the faucet wide open so that water is supplied faster than it can drain off. If this doesn't provide enough water to create the required column of water, use the Check Valve Assembly. (See "Clearing Slow Draining Sinks and Tubs")
3. Pump the Ram up to 10 lbs. of pressure to start.

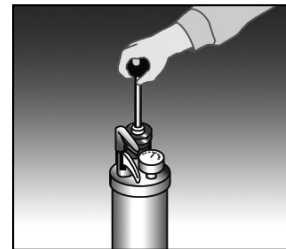

4. Wedge the tip of 4" Rubber Cone into the drain. If this will not provide a tight seal, use other attachments shown in Specific Applications.

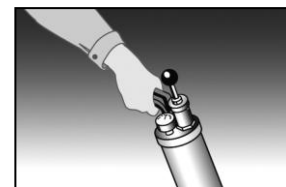

5. To avoid splash back, **press down firmly**, putting your weight behind the Ram. Then, SNAP trigger quickly for trip hammer effect.



6. Blockage will break up on impact.
7. If the blockage persists, gradually increase the pressure by 10 lb. increments until the blockage has been cleared. Most lines can be cleared using only 20 to 40 lbs of pressure.
8. Follow by flushing thoroughly with water to carry off waste particles.

SPECIFIC APPLICATIONS

Sinks

In sinks you must block the overflow vent with a wet rag or towel before firing the Water Ram to prevent splash back. Apply pressure to the rag or towel at the moment when you snap the trigger.



There must be some water in the basin, so that the nozzle of the Ram is under water when placed in the drain opening. Use low pressure at first to make sure you have splash back under control, then increase in 10 lb. increments until the stoppage has been cleared. Flush the line with warm water.

Combination Sinks

To unclog double compartment sinks, use the Water Ram in the sink section leading directly into the trap and stack. To avoid splash back, seal off adjacent sink using an expansion plug. If you do not have an Expansion Plug, block the adjacent drain by covering firmly with towel or rag.

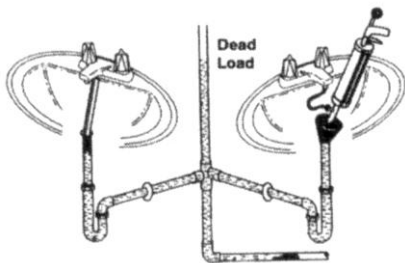

Bathtubs

Remove the pop-up cover from tub drain and position the Water Ram. Use low pressure at first to make sure splash back is under control. Make sure there is some water in the tub so that the tip of the Ram is under water when placed in the drain opening. If the water is draining too quickly, see "Clearing Slow Draining Sinks And Tubs."

If you're having difficulty with splash back, follow the same procedure as for clearing sinks. Remove the overflow screen and push 8 to 10 inches of thin, wet rag down the overflow and replace the screen.

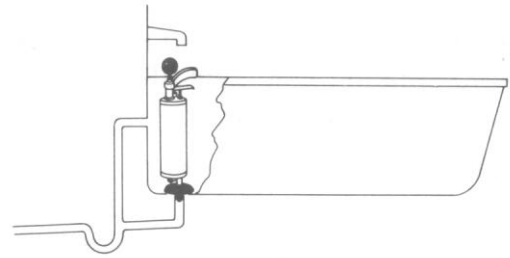

In some tubs, excellent results can be obtained by combining the caulking hose with the tapered Rubber Cone.

1. Unscrew the pop-up lever on the tub.
2. Thread the Lock Nut up the spindle two inches.
3. Thread the Rubber Cone back to the Lock Nut.
4. Thread the Caulking Hose onto the spindle, just in front of Cone.
5. Insert the Caulking Hose into the pop-up valve opening. This will aim the kinetic force directly down the drain. Be sure to cover the drain opening before snapping the trigger.

Clearing Slow Draining Sinks And Tubs

Turn the faucet wide open so that water is supplied faster than it can drain off. If this doesn't provide enough water to create the required column of water, use the optional Check Valve Assembly (G-CVK) as follows:

1. Remove the 4" Rubber Cone from the end of the Water Ram.
2. Thread the Check Valve Attachment onto the end of the Ram.
3. Thread the 4" Rubber Cone, or the appropriate size Tapered Plug or Expansion Plug, onto the end of the Check Valve Assembly.
4. Thread the Faucet Adapter or Threaded Adapter onto one end of the Water Supply Hose, then attach it to the faucet. Thread the other end of the hose to the Check Valve Assembly.
5. Place the tip of the Ram into the drain and pump it up to the desired pressure.
6. Turn the faucet wide open so that water is supplied faster than it can drain off.
7. With the tip of the Rubber Cone firmly sealing off the drain opening, the water from the faucet flows through the Check Valve Assembly and enters the pipe, then rises in the stack or vent. This creates a head pressure that helps the Ram clear the blockage.

8. Be sure to turn off the faucet before snapping the trigger.

Toilets

Toilet bowls have an oval shaped opening that can make it difficult to form a good seal around the 4" Rubber Cone. It often helps to stuff a rag around the cone. A better solution is to use an optional Toilet Attachment (KR-CA).

To use the Toilet Attachment:

1. Remove the 4" Rubber Cone from the end of the Water Ram.
2. Thread the Toilet Attachment onto the end of the Ram. Tighten the Lock Nut to secure the Toilet Attachment in position.
3. Hold the Ram over the bowl and press the Rubber Cone into the opening. Tilt it back to allow the cone to seat properly.



Start with a small amount of pressure at first to make sure splash back is under control. Press down firmly, putting your weight behind the Ram and snap trigger. If low pressure is not successful, increase it in 10 lb. increments until the line has been cleared.

If the toilet is only partly blocked, by an object such as a toothbrush or pencil, loosely wad up a page of newspaper and stuff it into the bowl. When the Ram is fired, the balled-up newspaper will break up the blockage and clear the line.

Two To Four Inch Sewers

When the Water Ram is used at the cleanout or floor drain, connect the Ram to an Expansion Plug. If you encounter a 4" floor drain that is a bit oversized for the 4" Expansion Plug, wrap a piece of gasket rubber around the expansion plug and make a snug fit before tightening the plug.

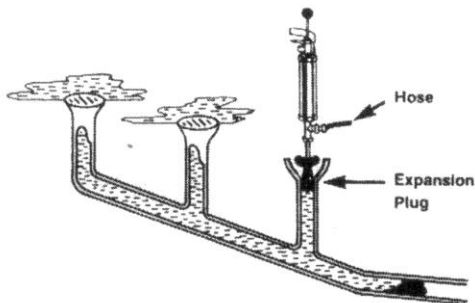

Where there is more than one drain opening, always apply the Ram where the water backs up first. Use the Check Valve Assembly to add water to the line. (See "Clearing Slow Draining Sinks And Tubs.") Do not discharge the Ram until the water appears on the floor at the next opening. Other drain openings should be covered to protect against splash back.

Extreme Blockages

If the line is severely blocked, insert the Caulking Hose furnished with Water Ram into the drain opening. An excellent seal can be made by caulking the hose into the drain by means of a wet rag. Then, while you hold the hose down, fire the Ram using 30 to 40 lbs of pressure.

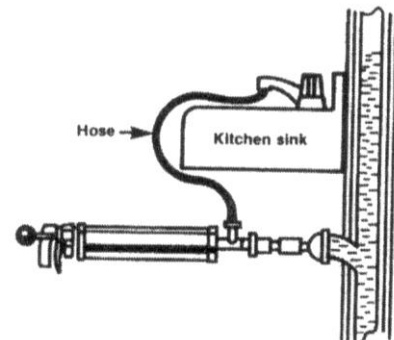

In extreme stoppages, remove the trap, attach a half-inch reducing coupling to drain pipe and connect the Ram. Attach the Water Supply Hose between faucet and Check Valve Assembly on Ram. Turn on faucet so that vent is filled with water. Two or three feet of water in the vent or stack should be sufficient to clear the blockage. Be sure to turn off the faucet before firing the Ram. Apply 50 to 75 lbs. of pressure. If pumping becomes difficult, attach an external compressor to the Schraeder valve. Do not exceed 80 lbs.

Maintenance

The leather seal (G-15) in the Water Ram's pump should be oiled every 3 to 6 months to keep it from drying out. This can be done by lifting the pump rod up and then applying a few drops of neat's foot (leather) oil through the air hole.

The seals in the pump will wear with time and use. If the Ram has difficulty holding pressure, you can easily replace all the seals at the same time using the Ram Repair Kit (Cat # KRRK).

The best method for cleaning rubber accessories is to wash them in hot water with soap or detergent.

TROUBLE SHOOTING GUIDE

| Problem | Probable Cause | Solution |
|-----------------------------------|---|---|
| Cannot clear drain. | No water in drain. | Water must be in the drain. Open water faucet to allow drain to back up. Turn off before firing Ram. Use optional Check Valve Assembly (G-CVK) to provide water in slow draining sinks and tubs. |
| | Not enough pressure. | Increase pressure in 10 lb. increments until stoppage is cleared. If pumping becomes difficult, attach external compressor to Schraeder valve. Do not exceed 80 lbs. |
| | Ram is not at the correct drain opening. | Ram must be used at the closest drain opening to the stoppage. |
| Getting splash back. | Seal is not tight enough | Push down on Ram as it is being fired for a tighter seal. |
| | | Use Tapered Plugs or Expansion Plug for a tighter seal. |
| | Wedge a rag around the Rubber Cone or Caulking Hose for odd shaped openings, or wrap a strip of rubber around an Expansion Plug to increase the diameter. | |
| | Overflow or other drain is not covered. | Cover overflow in sink or other drain opening in combination sinks. |
| Ram will not pump up to pressure. | Dry leather seal. | Leather seal must be lubricated every 3 to 6 months to keep it from drying out. To do so, lift the pump rod and apply a few drops of neat's foot (leather) oil to the seal through the air hole. |
| | Worn leather seal. | If the leather seal is completely worn, it must be replaced. It is recommended that the Valve Seat Washer (G-10) be replaced at the same time. Be sure to clean the inside of the Air Pump Cylinder (G-18) and Pump Bottom Cap (G-8) of any oil and residue before reassembling unit. |
| Ram will not hold pressure. | Worn seals. | Seals will wear over time. All seals may easily be replaced at the same time using the Ram Repair Kit (Cat # KRRK). Be sure to clean the inside of the Air Pump Cylinder (G-18) and Pump Bottom Cap (G-8) of any oil and residue before reassembling unit. |

KINETIC WATER RAM

Parts List and Schematic Diagram

| CAT. NO. | DESCRIPTION | CAT. NO. | DESCRIPTION |
|----------|-------------------------|----------|--|
| G-01 | Shank | G-35 | Flat Washer |
| G-02 | Locknut | G-36 | Roll Pin |
| G-03 | Cap Screw | G-38 | Bell Shaped Nut |
| G-04 | Sealing Washer | G-39* | Seat Washer |
| G-05 | Locknut | G-41 | 1/4" x 28 Fin Nut |
| G-06* | O-Ring | G-42 | Lifter Rod Guide |
| G-07 | Solder Ring | G-55 | Check Valve Assembly |
| G-08 | Pump Bottom Cap | G-55-1 | Check Valve Shank |
| G-09 | Pump Shaft | G-55-2 | Check Valve 1/2" Tee |
| G-10* | Valve Seat Washer | G-55-3 | Check Valve Adapter |
| G-11 | Spacer | G-55-4 | Check Valve Spring |
| G-12* | 1/4" x 20 Hex Nut | G-55-5 | Check Valve Ball |
| G-13* | 1/4" Lock Washer | G-55-6 | Check Valve Insert |
| G-14* | Cup Spreader | G-57 | O-Ring Container |
| G-15* | Leather Cup | G-CVK | Check Valve Assembly Kit (Contains G-45, G-46, G-55) |
| G-16 | Washer | KR-VIDEO | Instructional Video |
| G-17 | Pump Shaft Spring | | |
| G-18 | Air Pump Cylinder & Nut | | ACCESSORIES |
| G-19 | Air Chamber Cylinder | G-43-4 | 4" Rubber Cone |
| G-20 | Handle | G-43-6 | 6" Rubber Cone |
| G-21 | Schrader Valve | G-44 | Caulking Hose |
| G-22 | Roll Pin | G-45 | Supply Hose |
| G-23 | Set Screw | G-46 | Universal Faucet Adapter |
| G-24 | Ball Handle | G-48 | Set of 5 Drain Adapters |
| G-25* | "E" Ring | G-49/50 | Threaded Faucet Adapter |
| G-26* | Trigger Pin | G-52 | Extension Hose |
| G-27 | Trigger | KR-RK | Ram Repair Kit |
| G-28* | O-Ring | KR-CA | Toilet Attachment |
| G-29 | Guide | KR-CC | Carrying Case |
| G-30 | Pressure Gauge | 1-1/2EX | 1-1/2" Expansion Plug |
| G-31* | O-Ring | 2EX | 2" Expansion Plug |
| G-32 | Lifter Rod Connector | 3EX | 3" Expansion Plug |
| G-34* | Spring | 4EX | 4" Expansion Plug |

*These parts, plus Neat's Foot Oil, are included in KR-RK Ram Repair Kit.

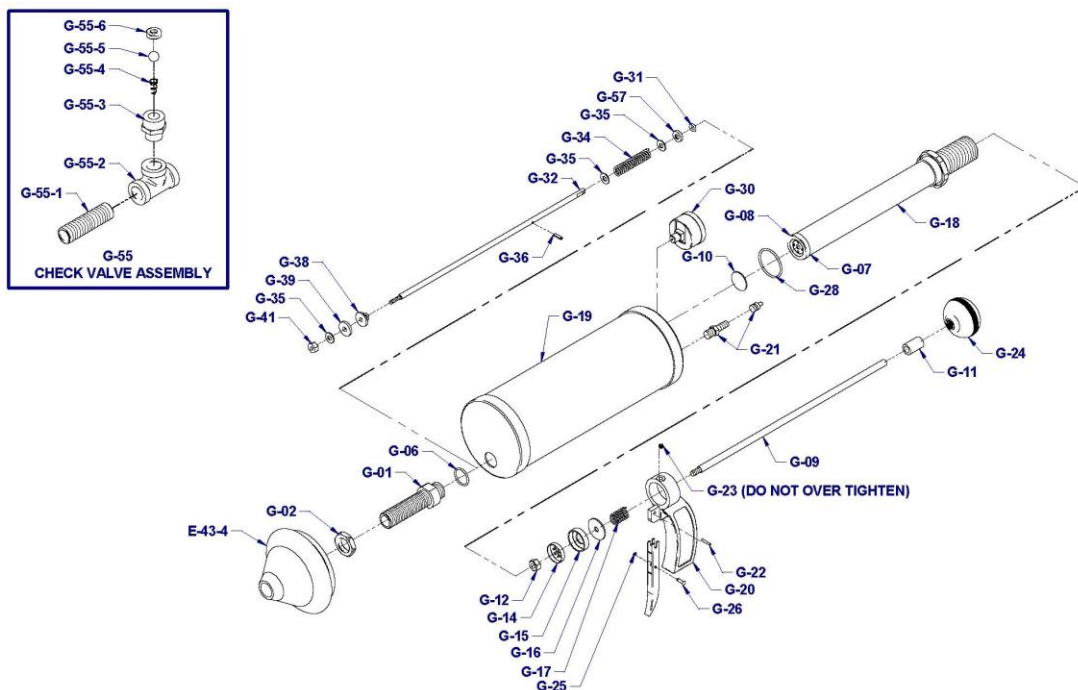

Kinetic Water Ram Limited Warranty

The Kinetic Water Ram carries a one-year warranty against defect or breakage except as noted below. Should any part break or fail to work properly in the year following purchase, it will be repaired or replaced at our discretion at no charge.

Some parts, such as seals, are subject to normal wear and are repaired or replaced within one year only if a flaw in the material causes failure.

Damage due to negligence, rust, exposure to corrosive chemicals, improper usage, failure to follow instructions, accidents, or alteration from original design is not covered by this warranty.

In order to handle any adjustment with a minimum of delay, please follow this procedure:

1. If for any reason the Kinetic Water Ram has to be returned to the factory, first contact us and we will assign a Return Merchandise Authorization (RMA) number. The RMA number must be affixed to the returned product, and any correspondence related to the return.
2. Ship freight prepaid, and you will be compensated for these charges if it is determined that the part is defective.
3. The Water Ram must be well wrapped and packaged to protect the finish. Standard fittings must be wrapped, and packed so as not to damage the Ram. Damage caused by poor packaging will be your responsibility.

If repairs are necessary due to conditions beyond our control, or if the item is out of warranty, we will do the work at the lowest possible cost, but a charge will be made.

This warranty is made in place of other warranties, expressed, statutory or implied, including those of merchantability and fitness for purpose.

This warranty gives you specific legal rights, and you may also have other rights which vary from state to state. Some states do not allow the exclusion of limitation of incidental or consequential damages, so these limitations may not apply to you.

General Wire Spring Co.

1101 Thompson Avenue
McKees Rocks, PA 15136